

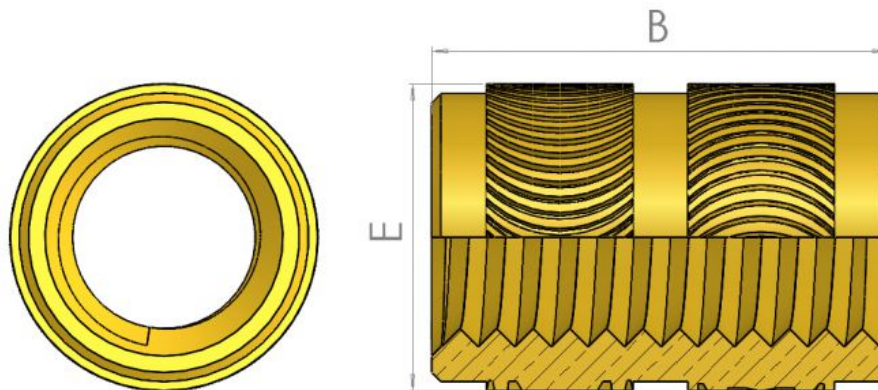

Series: 20108 Type: HL



Heatstake Insert for Polycarbonate

Part No.	Thread A	Ext. Diam. E	Length B	Hole dia. L+0.1	Min Wall W
HL020H040	M2.0	3.50	4.00	3.20	1.50
HL025H058	M2.5	4.40	5.80	4.00	1.80
HL030H058	M3.0	4.40	5.80	4.00	1.80
HL035H072	M3.5	5.20	7.20	4.80	2.20
HL040H082	M4.0	6.00	8.20	5.60	2.50
HL050H095	M5.0	6.80	9.50	6.40	3.00
HL060H127	M6.0	8.40	12.70	8.00	3.50
HL080H127	M8.0	10.00	12.70	9.60	4.50
HL100H127	M10.0	12.30	12.70	11.90	5.50

HL Heatcert Series provide a strong female threaded fixing in Polycarbonate and other "notch sensitive" brittle materials. These plastics often suffer from stress fractures as a consequence of the installation of screws or inserts with sharp profiles causing "hoop stress". The specially designed knurl has no sharp edges which reduces the possibility of hoop stress providing resistance to high pullout loads and torque resistance. Material and Finish:- Brass Self Colour (Nickel plated is available as special order) To Specify Use: Series No / Part No (eg 20108 HL030H058)

All information is given for guidance only and designers should satisfy themselves as to the suitability of the specification by requesting samples