

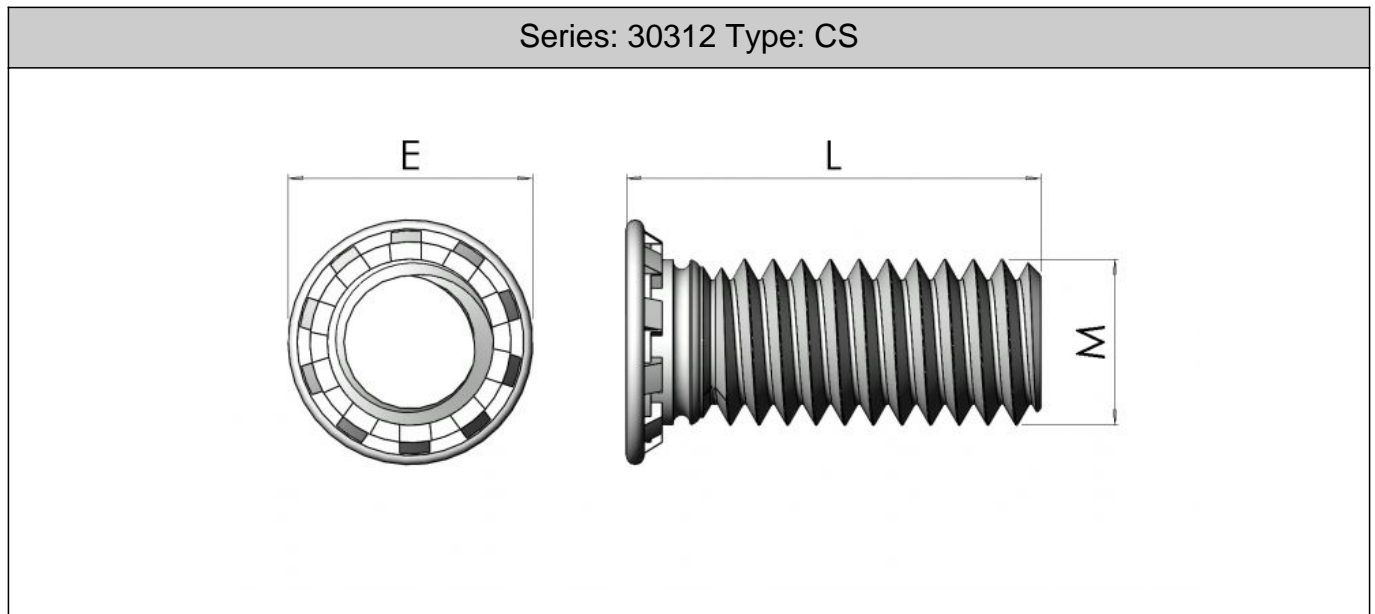

Continued from previous page...



Self Clinch Studs provide a strong male thread in sheet metal materials. They are squeezed into place using a press whilst supporting the reverse side. The clinching process is cleaner than traditional weld studs whilst having similar performance.

Materials & Finishes:-Heat Treated Carbon Steel Trivalent Zinc (code 60)304 Stainless Steel Self Colour (Code SS)400 Series Stainless Steel316 Stainless Steel Self Colour (Code A4, Available to order)

To specify use Series No / Part No / Length / Finish Code (eg 30312 M320 60)

Available Lengths

All information is given for guidance only and designers should satisfy themselves as to the suitability of the specification by requesting samples