

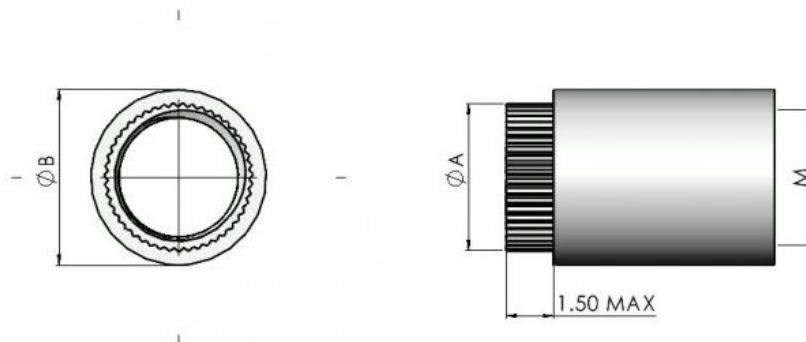

Series: 30318 Type: CBFE



Broaching Stand Offs For PCB

Part No.	Thread M	Through Hole	Suitable Sheet	Body Diam. B	Lead Diam. A	Hole Size
CBFE M3	M3	-	1.6	5.56	4.68	4.20
CBFE 3.6	-	3.6	1.6	7.14	5.87	5.40
CBFE 4.2	-	4.2	1.6	8.74	6.81	6.40

Legend	
*	Usually Available from Stock
**	Non-preferred (Possible Lead Times)
***	Special Order Only

Part	3	4	6	8	10	12	14
CBFE M3	*	*	*	*	*	*	*
CBFE 3.6	*	*	*	*	*	*	*
CBFE 4.2	*	*	*	*	*	*	*

Broaching Standoffs are for use in Circuit boards or thin sheet materials softer than RB-65. The broaching action during installation creates excellent retention in the board giving a secure mounting for components & hardware. Various lengths are available so boards can be stacked at the required distance. Non threaded versions are also available if preferred. Materials & Finishes Steel Electro Tin (Code CBFE) 303 Stainless Steel (Code CBSS)



Continued from previous page...

Series: 30318 Type: CBF E

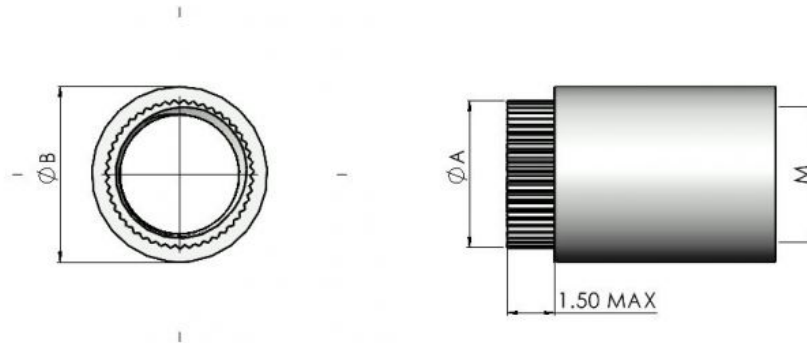

Length Options

All information is given for guidance only and designers should satisfy themselves as to the suitability of the specification by requesting samples