

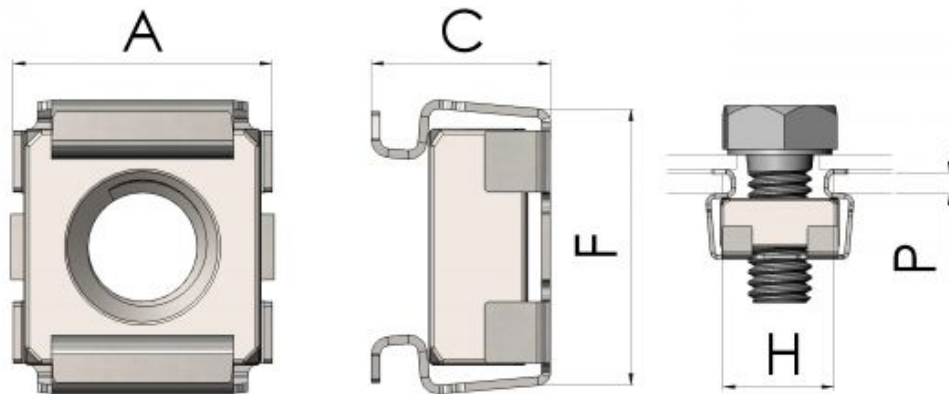

Series: 40111 Type: CN



Spring Steel Cage Nuts

Part No.	Thread M	Panel Range P	Dim. A	Dim. C	Hole Size H
M3 5330	M3	0.3-0.9	9.3	5.2	5.3
M3 5331	M3	1.0-1.6	9.3	5.9	5.3
M3 5332	M3	1.7-2.3	9.3	6.6	5.3
M3 5333	M3	2.4-3.1	9.3	7.4	5.3
M4 5340	M4	0.3-0.9	9.3	5.2	5.3
M4 5341	M4	1.0-1.6	9.3	5.9	5.3
M4 5342	M4	1.7-2.3	9.3	6.6	5.3
M4 5343	M4	2.4-3.1	9.3	7.4	5.3
M4 6741	M4	0.7-1.6	10.0	7.2	6.7
M4 6742	M4	1.8-2.6	10.0	8.2	6.7
M4 8340	M4	0.3-1.1	12.0	8.0	8.3
M4 8341	M4	1.2-1.6	12.0	8.5	8.3
M4 8342	M4	1.7-2.5	12.0	9.5	8.3
M4 8343	M4	2.6-3.5	12.0	10.5	8.3
M4 8344	M4	3.6-4.5	12.0	11.5	8.3
M4 9541	M4	0.7-1.6	13.2	8.7	9.5
M4 9542	M4	1.7-2.7	13.2	9.5	9.5



Continued from previous page...

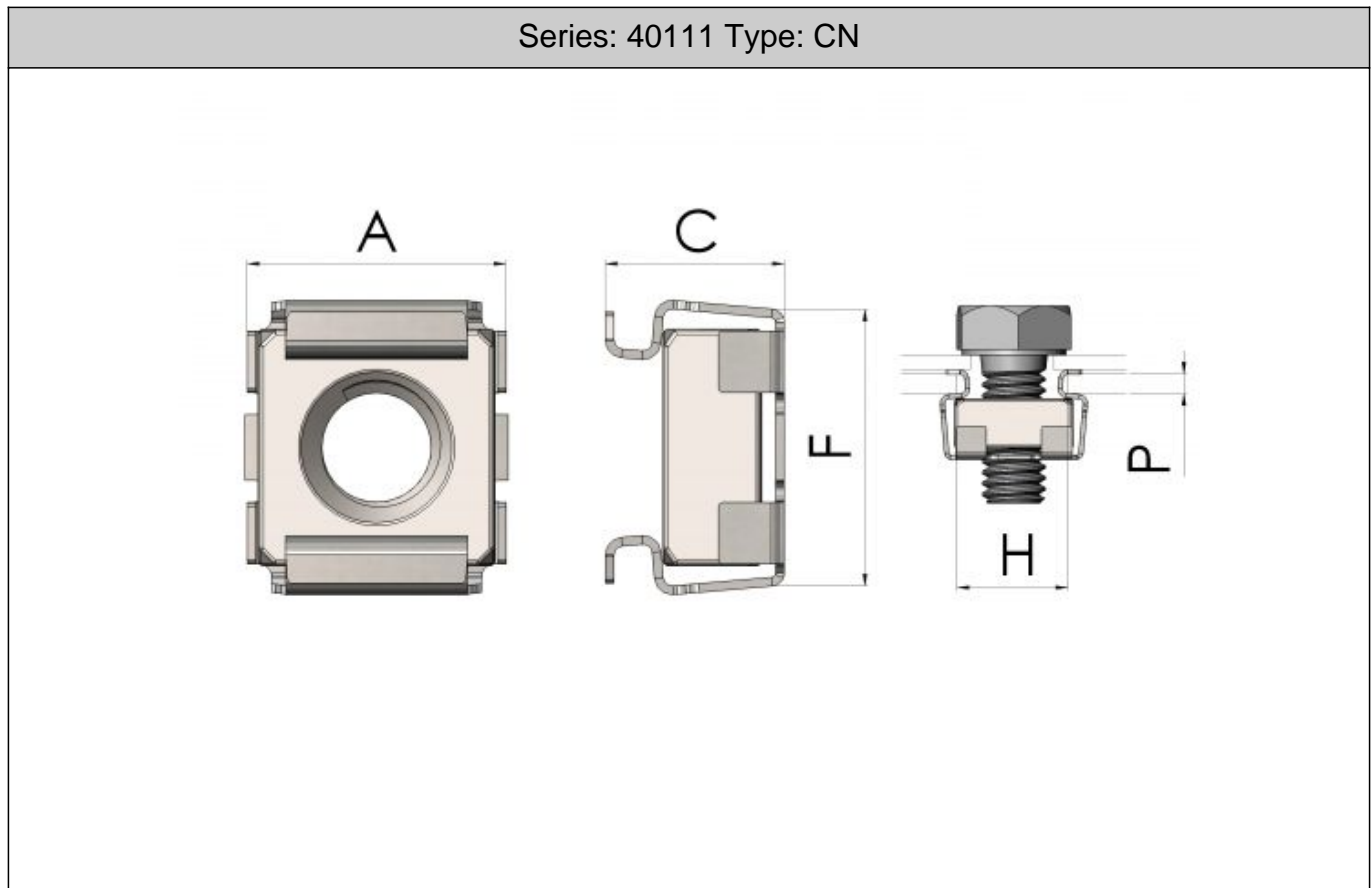

M4 9543	M4	2.8-3.5	13.2	10.2	9.5
M5 6751	M5	0.7-1.6	10.0	7.2	6.7
M5 6752	M5	1.8-2.6	10.0	8.2	6.7
M5 8350	M5	0.5-1.1	12.0	8.0	8.3
M5 8351	M5	1.2-1.6	12.0	8.5	8.3
M5 8352	M5	1.7-2.5	12.0	9.5	8.3
M5 8353	M5	2.6-3.5	12.0	10.5	8.3
M5 8354	M5	3.6-4.5	12.0	11.5	8.3
M5 9551	M5	0.7-1.6	13.2	8.7	9.5
M5 9552	M5	1.7-2.7	13.2	9.5	9.5
M5 9553	M5	2.8-3.5	13.2	10.2	9.5
M6 8360	M6	0.3-1.1	12.0	8.0	8.3
M6 8361	M6	1.2-1.6	12.0	8.5	8.3
M6 8362	M6	1.7-2.5	12.0	9.5	8.3
M6 8363	M6	2.6-3.5	12.0	10.5	8.3
M6 8364	M6	3.6-4.5	12.0	11.5	8.3
M6 9561	M6	0.7-1.6	13.2	8.3	9.5



Continued from previous page...

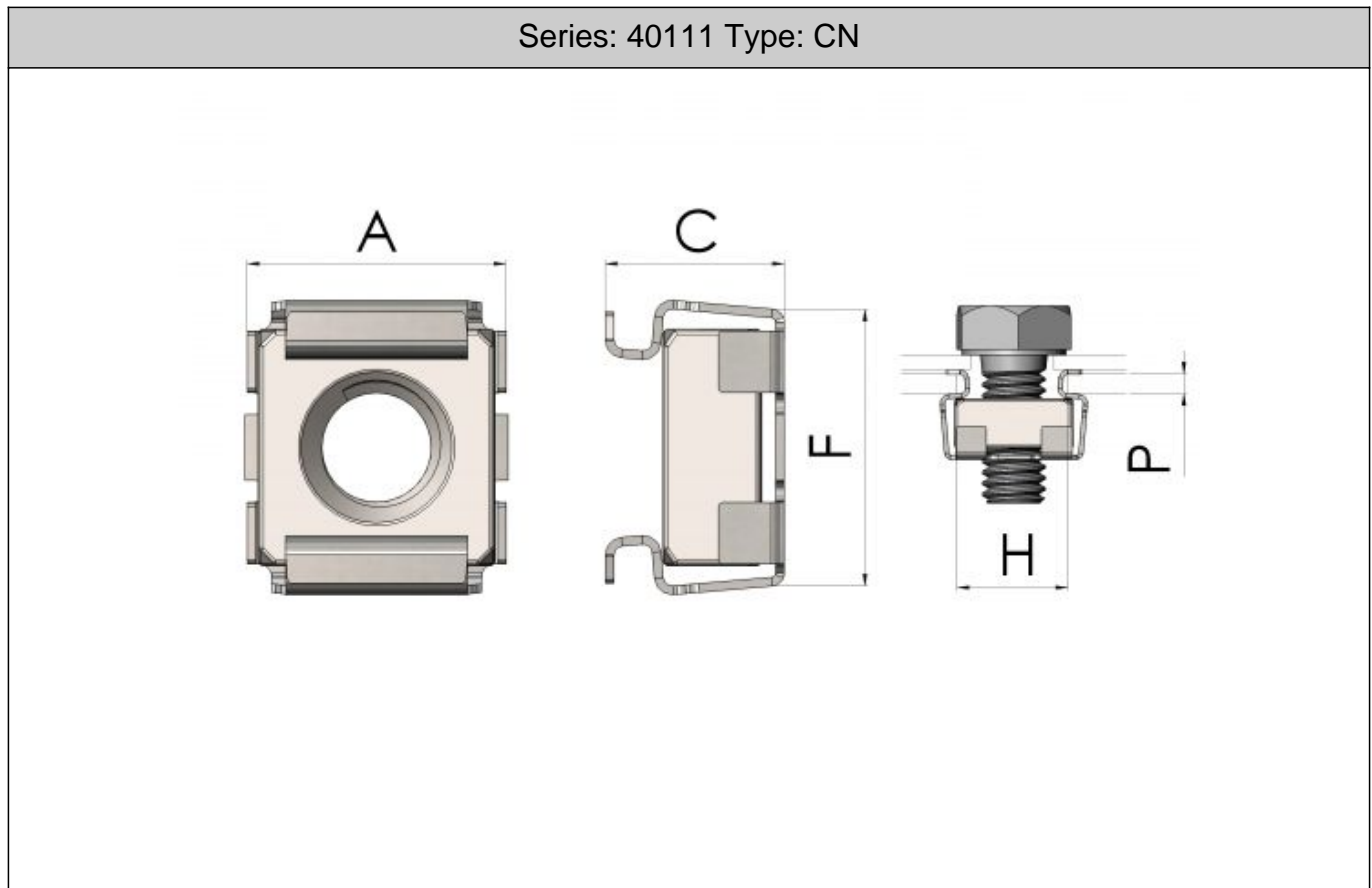

M6 9562	M6	1.7-2.7	13.2	9.3	9.5
M6 9563	M6	2.8-3.5	13.2	10.2	9.5
M6 12361	M6	1.0-1.7	16.0	10.4	12.3
M6 12362	M6	1.8-3.2	16.0	12.0	12.3
M6 12363	M6	3.3-4.7	16.0	13.5	12.3
M6 12364	M6	4.8-5.5	16.0	14.5	12.3
M8 12381	M8	1.0-1.7	16.0	10.4	12.3
M8 12382	M8	1.8-3.2	16.0	12.0	12.3
M8 12383	M8	3.3-4.7	16.0	13.5	12.3
M8 12384	M8	4.8-5.5	16.0	14.5	12.3
M8 14081	M8	1.0-1.7	20.0	13.5	14.0
M8 14082	M8	1.8-3.2	20.0	15.0	14.0
M8 14083	M8	3.3-4.7	20.0	16.5	14.0
M8 14084	M8	4.8-6.2	20.0	18.0	14.0
M10 14101	M10	1.0-1.7	20.0	13.5	14.0
M10 14102	M10	1.8-3.2	20.0	15.0	14.0
M10 14103	M10	3.3-4.7	20.0	16.5	14.0



Continued from previous page...

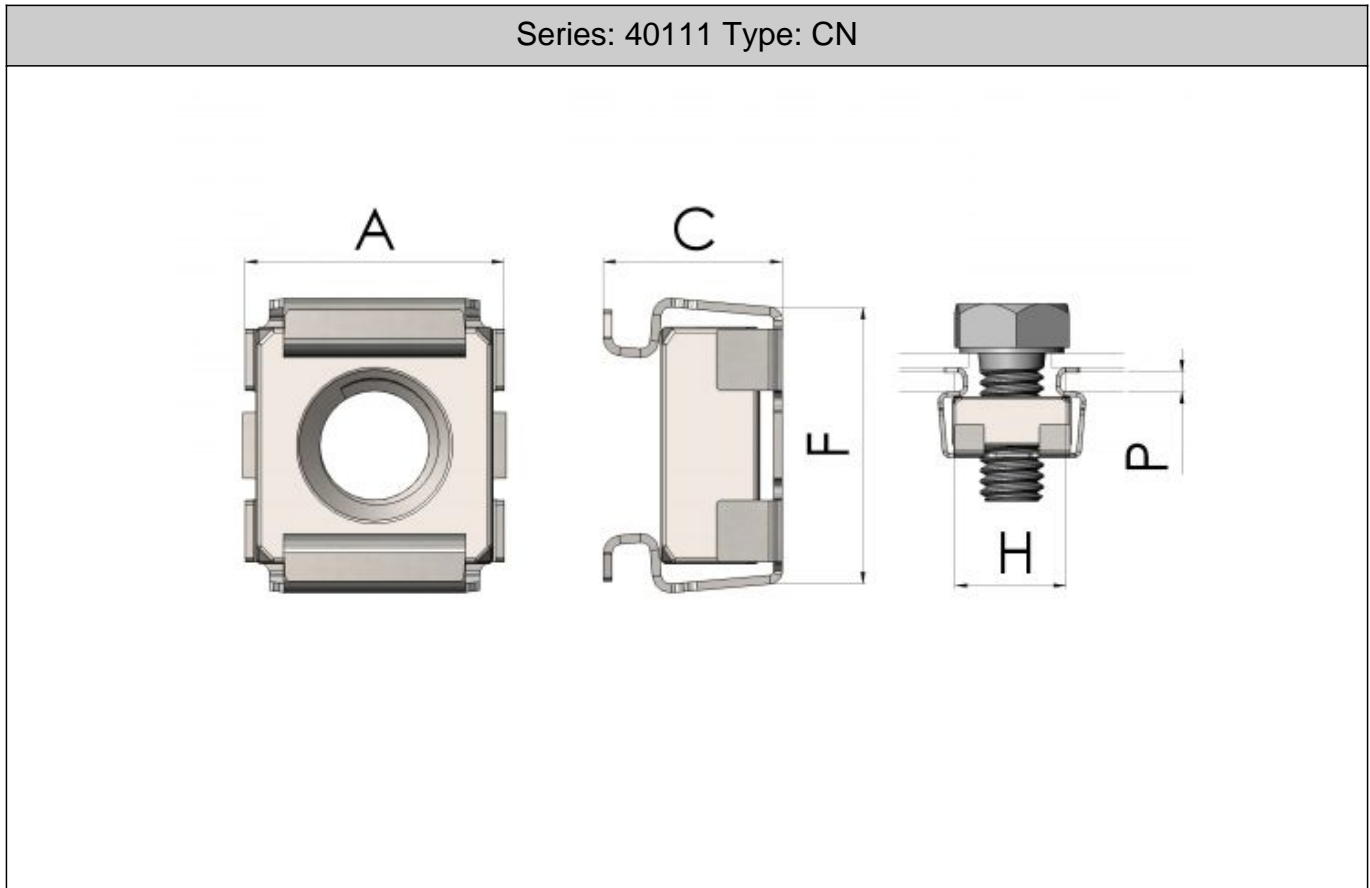

M10 14104	M10	4.8-6.2	20.0	18.0	14.0
M10 12311	M10	1.0-1.7	16.0	10.4	12.3
M10 12312	M10	1.8-3.2	16.0	12.0	12.3
M10 12313	M10	3.3-4.7	16.0	13.5	12.3
M10 12314	M10	4.8-6.2	16.0	14.5	12.3
M12 14121	M12	1.0-1.7	20.0	13.5	14.0
M12 14122	M12	1.8-3.2	20.0	15.0	14.0
M12 14123	M12	3.3-4.7	20.0	16.5	14.0
M12 14124	M12	4.8-6.2	20.0	18.0	14.0

Cage Nuts provide a simple but effective captive nut solution. This allows the nut to be held in place so the screw can be engaged later in the assembly process, or if access is not possible from both sides. The square nut floats in the cage allowing for mis-alignment of panels in assembly. Typical applications are 19" server cabinets and other metal enclosure cabinets.
 Material: Nut Mild Steel Cage C67S Spring Steel Finish: Trivalent Zinc