

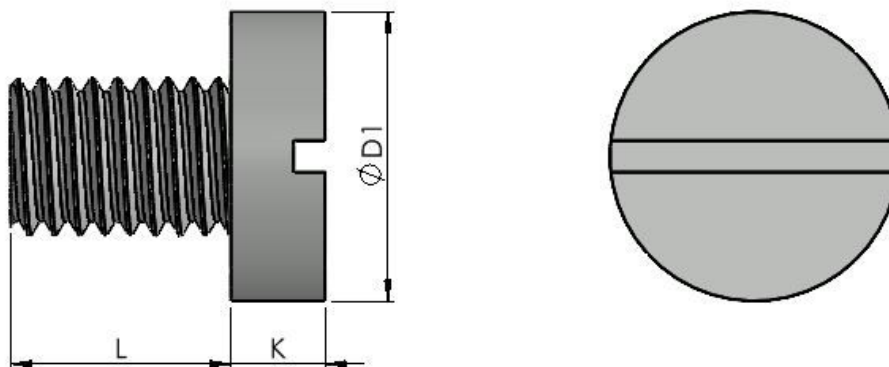

Series: 10603 Type: - DIN 85



Slotted Pan Head

Part No.	Thread	D1	K
10603 M3**	M3	6.00	1.80
10603 M4**	M4	8.00	2.40
10603 M5**	M5	10.00	3.00
10603 M6**	M6	12.00	3.60

Legend	
*	Usually Available from Stock
**	Non-preferred (Possible Lead Times)
***	Special Order Only

Thread/Length	6	8	10	12	16	20	25	30	35	40	45	50
M3	*	***	*	*	***	***	***	***	***	***	***	***
M4	***	***	*	*	*	***	*	*	***	***	***	*
M5	***	***	***	***	***	***	*	***	*	***	***	***
M6	***	***	***	*	*	***	***	***	***	***	***	***

Machine Screws are round bodied, metric threaded fasteners that can be used either with a nut or with a pre-tapped hole in metal applications.

Material/Finish/Code:

Steel - Zinc Clear - 60Stainless Steel A2 - Self Colour - SSStainless Steel A4 -Self Colour - A4

To get the part number replace ** with the length found in the tables below followed by the finish code:



Continued from previous page...

Series: 10603 Type: - DIN 85

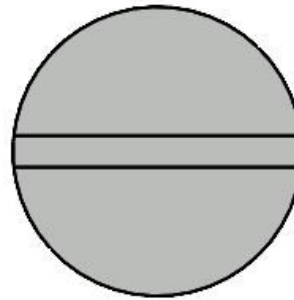
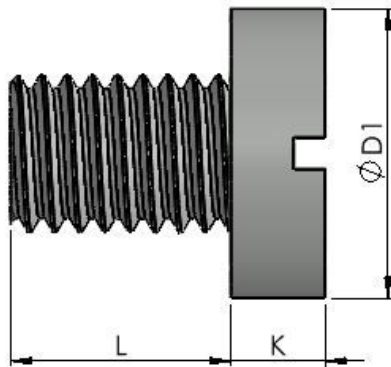

All information is given for guidance only and designers should satisfy themselves as to the suitability of the specification by requesting samples