

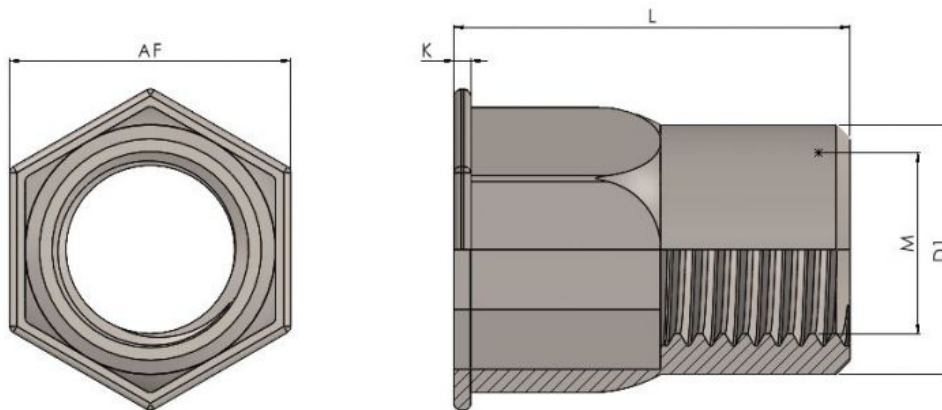

Series: 30204 Type: RHHE Steel



## Rivet Nut Reduced Head Half Hex Body (Metric Hole)

Part No	Thread M	Grip Range	Hole Size AF	D1	AF	K	L
RHEE03-1	M3	0.5-1.5	5.1	4.9	6.0	0.5	9.3
RHEE03-2	M3	1.5-2.5	5.1	4.9	6.0	0.5	10.0
RHHE04	M4	0.5-2.0	6.1	5.9	7.0	0.5	12.0
RHHE05	M5	0.5-3.0	7.1	6.9	8.0	0.5	13.0
RHHE06	M6	0.5-3.0	9.1	8.9	10.0	0.6	16.0
RHHE08	M8	0.7-3.0	11.1	10.9	12.0	0.6	16.5
RHHE10	M10	0.8-3.5	13.1	13.0	14.0	0.8	20.0

Half Hex Rivet Nuts combine excellent torque resistance and fast assembly due to the round front end which eliminates the need to orientate the hex flats. The reduced head provides an almost flush surface in a punched hole.

Materials and Finishes (Code):  
 Steel, Trivalent Zinc (60)

**All information is given for guidance only and designers should satisfy themselves as to the suitability of the specification by requesting samples**