

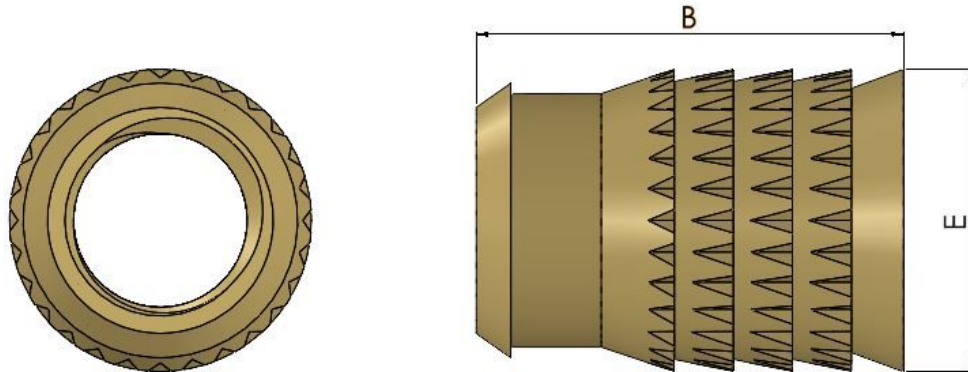

Series: 20103 Type: MS



### Press in Insert for Thermoset

Part No.	Thread	Dim E	Length B	Hole Diam	Min Wall&nbsp;
MS020H031	M2	3.5	3.1	3.0-3.3	1.4
MS020H042	M2	3.5	4.2	3.0-3.3	1.4
MS025H041	M2.5	4.3	4.1	3.7-4.0	1.7
MS025H052	M2.5	4.3	5.2	3.7-4.0	1.7
MS030H041	M3	4.3	4.1	3.7-4.0	1.7
MS030H052	M3	4.3	5.2	3.7-4.0	1.7
MS035H041	M3.5	5.3	4.1	4.6-5.0	2.2
MS035H070	M3.5	5.3	7.0	4.6-5.0	2.2
MS040H056	M4	6.3	5.6	5.4-5.9	2.5
MS040H085	M4	6.3	8.5	5.4-5.9	2.5
MS050H066	M5	7.05	6.6	6.0-6.5	2.9
MS050H101	M5	7.05	10.1	6.0-6.5	2.9
MS060H077	M6	8.65	7.7	7.7-8.2	3.2
MS060H123	M6	8.65	12.3	7.7-8.2	3.2
MS080H083	M8	11.0	8.3	10.2-10.6	4.2
MS080H138	M8	11.0	13.8	10.2-10.6	4.2

MS inserts have a coarse knurl pattern making them ideal for all types of thermoplastic. They can be inserted by heat, ultrasonic press or simply pressing into the boss.

Materials and Finishes: Brass Self Colour

To Specify Use: Series No / Part No (eg 20103 MS020H031)

**All information is given for guidance only and designers should satisfy themselves as to the suitability of the specification by requesting samples**